

## NEWS

- X's are Shipping [1st X.....](#)



© fxguide LLC, 2011

## NEWS

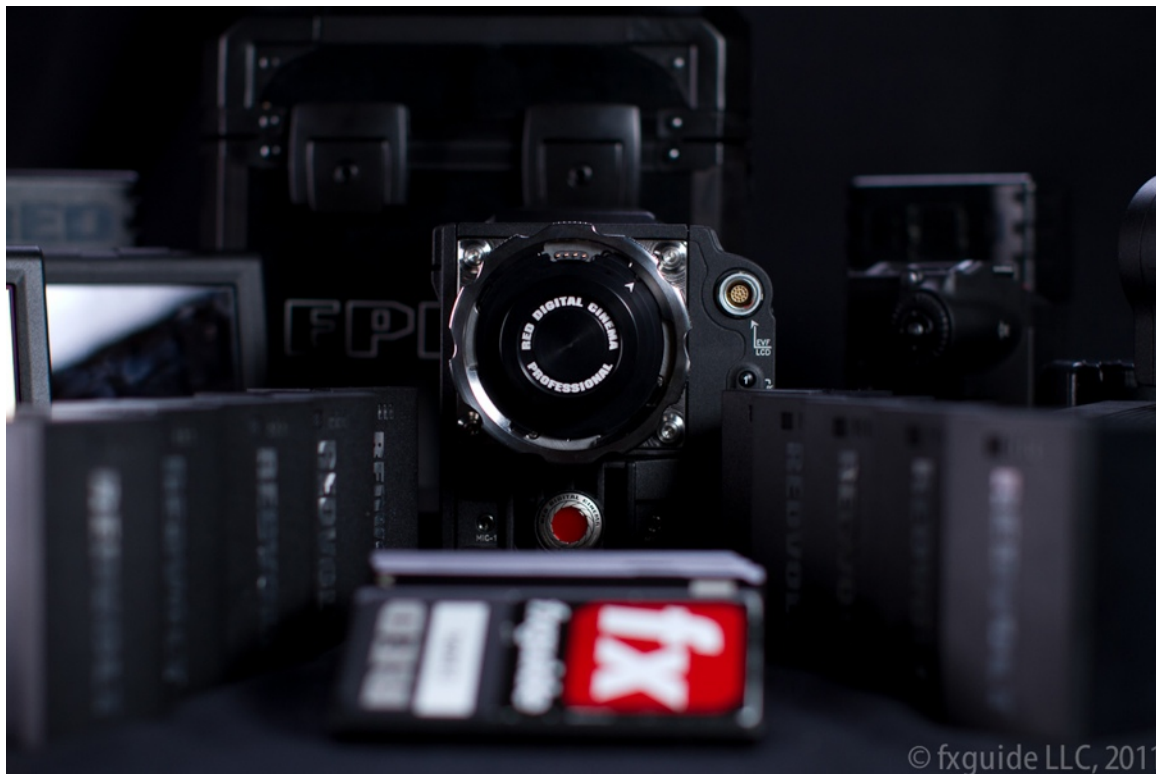

## NEWS



- [RED Roadmap...](#)

EPIC-M- shipping

EPIC-X- shipping

Scarlet

REDray

Dragon update

RED projection

Monstro 645 DSMC

Monstro 617 DSMC

Surprise #1

Surprise #2

We reserve the right to change everything as needed...

Jim



## NEWS

- [Red EPIC Canon mount test drive review | fxguide](#)





## NEWS



## NEWS





## RC Podcast Episode #97 Shownotes

### NEWS

- [Module Ship Dates....](#)

Pro I/O - Shipping begins in January

9" LCD - Shipping begins in January

BOMB EVF - A whole whack load of them shipping this week.

REDMOTE - Next batch comes in end of September. Out of Backorder end of October.

DSMC Side Handle - Catching up... should be out of existing backorder in 2 weeks and healthy supply in 3 weeks.

Canon Mount - Next batch in 2 weeks. Healthy production October.

Nikon Mount - Awaiting next revision. Still in Beta testing. Next batch November, full production in December.

Quad REDVOLT module - End of October (part of Epic X Kit)

Dual REDVOLT module - Mid December

Quad REDVOLT charger - End November

#### [Message about STORM](#)

[STORM | Your On-Set Digital Lab | The Foundry](#)

The current release - STORM 1.0v4 - is the end of the STORM roadmap for us  
STORM will remain available to purchase until the end of September after which we will maintain the software until the end of October 2012.



## NEWS

- **Sony IBC announcements**

### **F65 Pricing**

The F65 digital motion picture camera line-up is scheduled to be available in January direct from Sony: The F65, with viewfinder for \$65,000; the F65RS (Built in Rotary Shutter Model), with viewfinder for \$77,000; and SR-R4 dockable recorder for \$20,000.

SR-R4 - which attaches to the camera to record directly to an SRMemory card of 256 GB, 512 GB or 1TB capacity with data security and sustained throughput of 5.5 Gbps.

Sony is now unveiling a powerful new capability for the F65/SR-R4 combination - the ability to switch recording between 16-bit linear RAW File and MPEG-4 SStP File modes. Users can configure the camera on a project-by-project basis, selecting either 16-bit linear RAW File for ultimate quality acquisition or high speed operation at up to 120FPS, or MPEG-4 SStP File (HDCAM SR native) for exceptional quality HD recording. MPEG-4 SStP File also provides full compatibility for viewing, offline and post production using either the free Sony PC or MAC viewer or products using the new Sony Software Development Kit.







### NEWS

- **Sony F65 continued...**

#### **F65 – powerful new features for HD acquisition**

At IBC, Sony will also unveil a powerful new capability for the F65/SR-R4 - the ability to switch recording between 16-bit linear RAW and MPEG-4 SStP modes. Users will be able to configure the camera on a project by project basis, selecting either 16-bit linear RAW for ultimate quality acquisition or high speed operation at up to 120fps, or MPEG-4 SStP (HDCAM-SR native) for exceptional quality HD recording. MPEG-4 SStP also provides full compatibility for viewing, offline and post production using either the free Sony PC or MAC viewer or products using the Sony SDK (Software Development Kit) such as Final Cut Pro V7, Avid Media Composer, Avid Symphony, Sony Vegas, Baselight and Da Vinci Resolve.

#### **Open platform RAW file-based workflow**

In order to facilitate end-to-end workflows at 4K, Sony is also adopting a similar open strategy of providing SDKs to enable alliance partner manufacturers to integrate F65 RAW workflow into their extensive line-up of production and post production tools. The SDKs will allow the user to extract the required resolution from the original RAW file, for example HD for off-line and 4K for final post production. Key partners implementing this RAW workflow will include Adobe® Premiere® Pro, AJA, Apple, ASSIMILATE, Avid's Media Composer®, Blackmagic Design, Colorfront, Digital Film Tree, FilmLight, Fotokem Nextlab, Image System™, LightIron, Quantel, Sony Vegas™ Pro, The Foundry, The PixelFarm® and YoYotta.

## NEWS

- [HELL AND BACK AGAIN Trailer on Vimeo](#)

The trailer for Danfung Dennis's much anticipated Documentary, embedded in the US Marines Echo Company into the front line in Afghanistan with his 5DMkII has been released. Its screening from October.. check your local guides & follow danfung on twitter [twitter.com/danfung](http://twitter.com/danfung)

An interview with Danfung after he shot this project can be found on 'The Red Centre' Episode 50.

[red centre #050 | fxguide](#)



## IBC NEWS

- [Blackmagic Design: DaVinci Resolve 8.1](#) - Late September

new layer node composite effects  
 ACES colorspace support  
 compatibility for Avid AAF and round trip with Avid Media Composer™  
 Final Cut Pro 7 clip size and position support  
 new copy commands for grades  
 upgraded EDL features  
 support for UltraStudio 3D for Thunderbolt™  
 compatibility with the 2011 MacBook Pro 15" computer. Woot!

DaVinci Resolve 8.1 will be available in September 2011 as a free download for all current DaVinci Resolve customers.

- Davinci Resolve for Windows Due Q1 2012





## IBC NEWS

- [Blackmagic Design: Intensity Extreme Thunderbolt](#)

### Intensity Extreme - \$299

Intensity Shuttle, the world's first 10 bit HD/SD editing solution for to feature lightning fast Thunderbolt™ technology. Simply plug in Intensity Extreme to get incredible quality HDMI, component video, s-video and composite 10 bit capture and playback for Thunderbolt™ based computers. The perfect solution for videographers, Intensity Extreme includes SD/HD capture and playback in compressed and uncompressed video quality. Better still, this revolutionary new device is compatible with Final Cut Pro 7™, Adobe Premiere Pro™, Adobe After Effects™, Nuke™, DaVinci Resolve and more. **Shipping Q4 2011.**

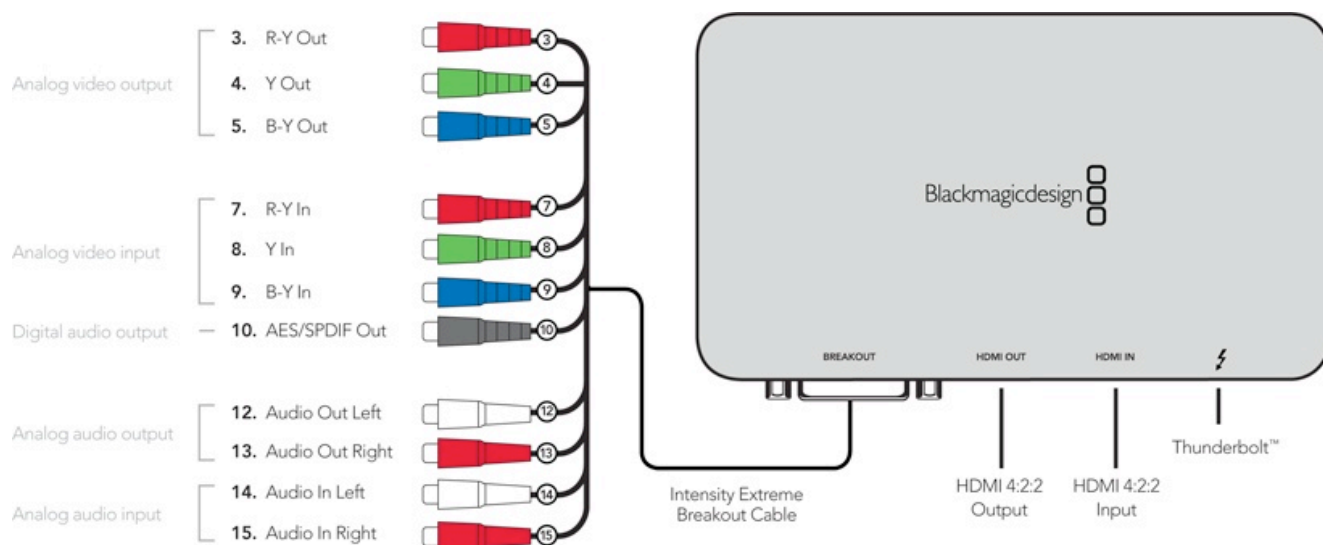

## IBC NEWS

- [Red rocket in Sonnet Thunderbolt chassis with Adobe Premiere](#)



- [Sonnet – Thunderbolt Storage, Adapters & Expansion Boxes](#)



## IBC NEWS

- [SideKick HD - Fast Forward Video](#)

With its small footprint, brilliant full-color screen, intuitive controls, and flexible mounting options, SideKick HD makes it easy to capture the perfect shot, even in challenging conditions.

- 1 Mount SideKick HD anywhere, with either the battery or cable option.
- 2 Select your preferred video input: HD/SDI or HDMI.
- 3 Capture every detail with automatic recording and frame-rate- and resolution-sensing capabilities.
- 4 Confirm that you got the shot with the 4.3" on-board confidence monitor and its simple playback options.
- 5 Increase record times with larger-capacity non-proprietary 2.5" SATA solid-state drives.





## GEAR

- [Spyder Jib](#)

At this time we are seeking a select group of beta testers to evaluate the Spyder Jib before general release. Please contact us if you are interested.

Projected msrp of the Spyder jib is \$2,995 subject to change.

The modified motion head msrp is \$595 also subject to change.



## GEAR

- Meduza 3D Camera [Camera » Meduza Sales](#)

The Meduza camera is the first and only professional quality Stereoscopic digital 3D camera ever made.

**Professional should be defined as reliable, capable of being ready in seconds not hours, interchangeable lenses, precise variable inter-axial (the distance between the lenses) and precise computer controlled and programmable variable convergence.**

**No other camera made other than Meduza meets these criteria. Meduza is a single camera, with a single set of electronics and a single set of controls that powers two imaging sensors at the same time. It borrows on no pre-existing technology, or system, it is new and truly innovative in all regards.**

Welcome to the world of Meduza

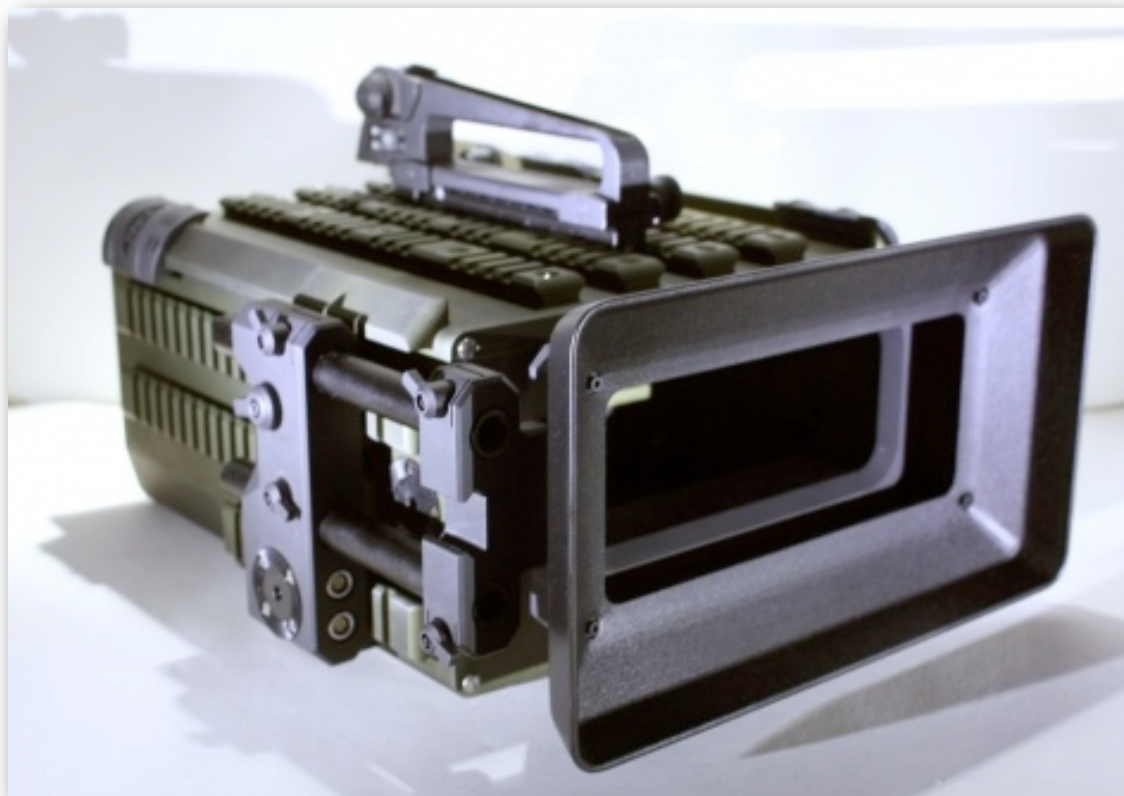

## GEAR

- Meduza 3D Camera [Camera » Meduza Sales](#)

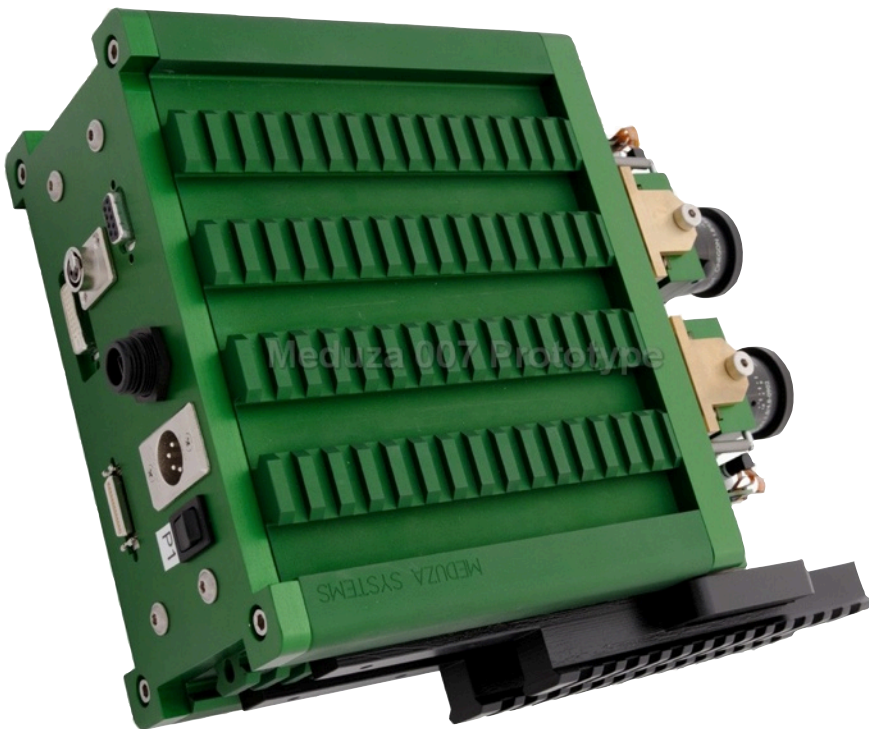
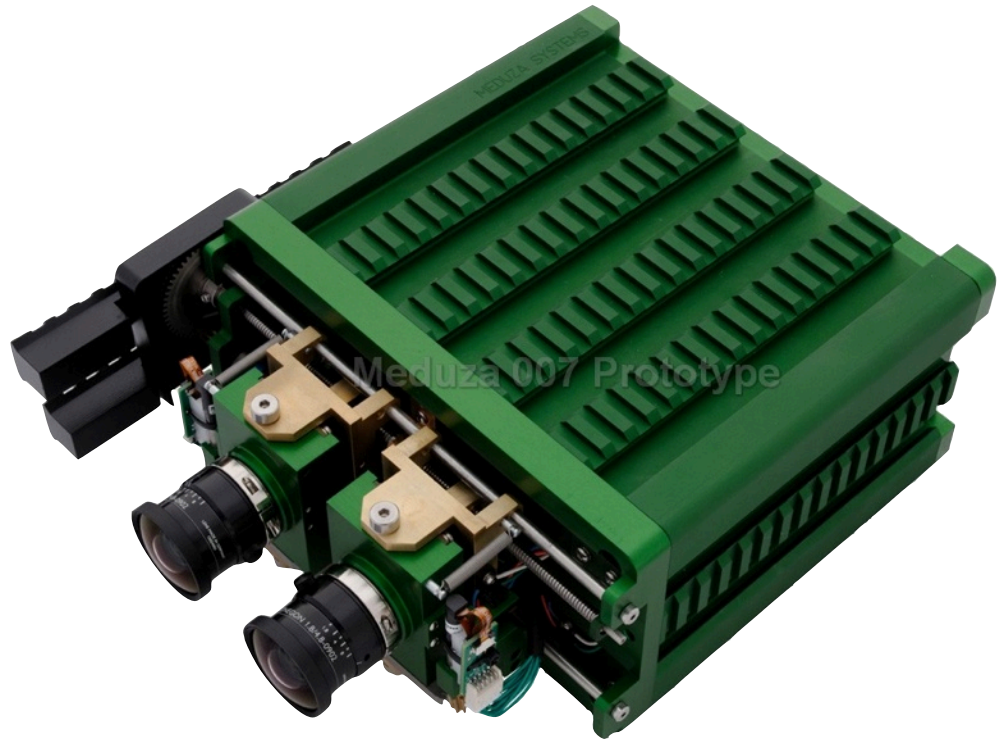



## GEAR

- [Blackmagic Design: Mini Converters Models](#)

SDI to HDMI, HDMI to SDI, Analog to SDI, SDI to Analog all \$595



## GEAR

### • [Atomos - Atomos Connect Converters](#)

- internal battery,
- Sony NP battery mount
- Canon and Panasonic mounting compatibility with suitable battery-plate adaptors
- Internal battery can power converter for two hours
- External battery (2-cell, NP-470-type) can power a converter for 15 hours (6-cell for up to 36 hours)
- Internal battery can be charged from external battery
- Built-in test pattern generator

Connect converters will be available in late 2011 for €249 / £219GBP / \$349 USD.



## GEAR

- <http://xumeadapters.com/>



**XUME**<sup>TM</sup>  
Filter Mounting System

Xume Quick-Release Adapters free you from the tedium and frustration of changing filters while clients wait or as the perfect light slips away. Never miss a shot or compromise your creativity again. Use the filter you want on the lens you want, when you want. **Great for use with polarizers or variable NDs.**

**Currently just 77mm adapters**

**Pro kit (2 lens adapters, 4 filter adapters) \$105, extra lens adapters \$32**

**Enter code "The RC" in the store for 10% off**





## GEAR

- [Pincher](#) \$130

The Pincher is a universal HDMI cable restraint for DSLR's. It is the perfect solution for keeping your HDMI cable in place. It includes the pincher device and a mounting bar that will allow you to use it out of the box on the [Zacuto Gorilla Plate](#) or [DSLR Baseplate](#).



## GEAR

- **Tangent Devices Element** [Tangent Devices / Element](#)

Modular Grading control surface. Knobs, trackballs, buttons & machine control  
Set of controls are rumored to be between \$3,500 & \$500

Solid aluminium construction, USB bus powered.

### Apple Color

BlackMagic Design Rsolve

Assimilate SCRATCH

**Cintel** FLOW & COLORFLOW

**Colorfront** On Set Dailies

**DFT** FLEXXIT

**Marquise** OCEAN, RAIN & MIST

Pixel Farm PF Clean

**SGO** Mistika

Yoyotta Yoyo

